

Technical Data

Specifications & Capacities

90 | RT

Telescopic Boom Rough Terrain Crane
90 US ton



CAUTION: This material is supplied for reference use only. Operator must refer to in-cab Crane Rating Manual and Operator's Manual to determine allowable crane lifting capacities and assembly and operating procedures.

Table Of Contents

Boom, Attachments, and Upper Structure	1
Boom	1
Boom	1
Boom Wear Pads	1
Boom Head	1
Boom Elevation	1
Auxiliary Lifting Sheave	1
Hook Blocks and Balls - Optional	1
Fly - Optional	1
Fly Extensions - Optional	1
Fly Controls	1
Operator's Cab and Controls	1
Swing	3
Electrical	3
Load Hoist System	3
Load Hoist Performance	3
Main and Auxiliary Winches	3
Hydraulic System	3
Counterweight	3
Carrier	4
General	4
Outriggers	4
Steering and Axles	4
Suspension	4
Tires and Wheels	4
Brakes	4
Electrical	4
Engine	4
Transmission	4
Fuel Tank	5
Hydraulic System	5
Pump Drive	5
Maximum Speed	5
Paint	5
Additional Equipment Options	5
Gradeability	5
Axle Loads	5
General Dimensions	6
Working Range Diagram	7
Main Boom + Fly	7
Boom Extend Modes	8
Main Boom Lift Capacity Charts - Imperial	9
28,800 lb Counterweight - Fully Extended Outriggers - 360° Rotation	9
Fly Attachment Lift Capacity Charts - Optional	10
28,800 lb Counterweight - Fully Extended Outriggers - 360° Rotation	10
155 ft Main Boom Length	10

Main Boom Lift Capacity Charts - On Tires	11
28,800 lb Counterweight - On Tires - Stationary - Boom Centered Over Front Between Tire Tracks	11
28,800 lb Counterweight - On Tires - Pick & Carry (Creep) - Boom Centered Over Front	12
28,800 lb Counterweight - On Tires - Pick & Carry (2.5 mph) - Boom Centered Over Front	13
Main Boom Lift Capacity Charts - 85% - Metric	14
13.2t Counterweight - Fully Extended Outriggers - 360° Rotation	14
Fly Attachment Lift Capacity Charts - Optional	15
13.2t Counterweight - Fully Extended Outriggers - 360° Rotation	15
47.24m Main Boom Length	15
Main Boom Lift Capacity Charts - On Tires	16
13.2t Counterweight - On Tires - Stationary - Boom Centered Over Front Between Tire Tracks	16
13.2t Counterweight - On Tires - Pick & Carry (Creep) - Boom Centered Over Front	17

Boom, Attachments, and Upper Structure

■ Boom

Design - Five section, formed construction of extra high tensile steel consisting of one base section and four telescoping sections.

Boom

- 40.6- 155 ft (12.3- 47.2m) five section full power boom
- Two boom extend modes (EM1 and EM2), controlled from the operator's cab, provide superior capacities by varying the extension of the telescoping sections. EM1 mode extends sections T2, T3, and T4 proportionally to a 126.4 ft (38.5m) boom length. Next section T1 extends to reach full 155 ft (47.2m) boom length. EM2 mode extends the T1 section to reach a 69.2 ft (21.1m) boom length. Next sections T2, T3, and T4 extend proportionally to reach the full 155 ft (47.2m) boom length.
- Mechanical boom angle indicator
- Maximum tip height is 164.6 ft (50.2m).

Boom Wear Pads

- Wear pads with Teflon inserts that self- lubricate the boom sections
- Bottom wear pads are universal for all boom sections
- Top wear pads are universal for all boom sections

Boom Head

- Five 16.5 in (41.9cm) root diameter nylon sheaves to handle up to ten parts of line
- Easily removable wire rope guards
- Rope dead end lugs on each side of the boom head
- Boom head is designed for quick- reeve of the hook block
- Wind speed indicator
- Aviation obstruction solar marking light and flag - optional

Boom Elevation

- One double acting hydraulic cylinder with integral holding valve
- Boom elevation: - 2.6° to 80°

Auxiliary Lifting Sheave

- Single 16.5 in (41.9cm) root diameter nylon sheave
- Easily removable wire rope guards
- Does not affect erection of the fly or use of the main head sheaves

Hook Blocks and Balls - Optional

- 27 ton (25mt) 1 sheave quick- reeve hook block with safety latch
- 60 ton (55mt) 3 sheave quick- reeve hook block with safety latch
- 88 ton (80mt) 5 sheave quick- reeve hook block with safety latch
- 110 ton (100mt) 6 sheave quick- reeve hook block with safety latch
- 10 ton (9.1mt) swivel and non- swivel hook balls with safety latch

Fly - Optional

- 35- 58 ft (10.7- 17.7m) two piece bi- fold lattice fly, stowable, offsettable to 0°, 15°, 30°, and 45°. Maximum tip height is 221.4 ft (67.5m).

Fly Extensions - Optional

- One 16 ft (4.9m) lattice extension, to be mounted between the boom head and fly options. Maximum tip height is 237 ft (72.3m).

Fly Controls

- One man assembly, minimizing ladder climbs
- Control box with fly assist and boom hoist cylinder switches located on front frame
- Sure- lock system prevents fly from ever being completely unpinned during assembly
- Speed screws for boom head and pivot point

■ Operator's Cab and Controls

Environmental Cab - Fully enclosed, one person cab of tubular and sheet steel structure with formed plastic interior panels.

Equipped with:

- Tinted and tempered glass windows
- Extra- large fixed front window with time delayed windshield wiper and washer
- Swing up roof window with windshield wiper and washer
- Sliding left side door with large fixed window
- Sliding right side window and pop- out rear window for ventilation
- Six way adjustable, cushioned seat with seat belt and two storage compartments
- Diesel fired warm- water heater with ten air ducts for front windshield defroster and cab floor
- Air Conditioning - Integral with cab heating system utilizing the same ventilation outlets and automatic temperature control (ATC)
- Adjustable sun screen
- Dome lights with red nighttime reading LED's
- Cup holder
- Fire extinguisher
- Two position travel swing lock
- AM/FM radio
- Tilting cab (0° - 20°)

Engine Dependent Warm- Water Heater - Optional - With air ducts for front windshield defroster and cab floor

Steering Column - Pedestal type with dual tilting functions for operator comfort. Column includes the following controls and indicators:

- Horn button
- Turn signal switch
- Driving light switch
- Transmission gear selector
- Transmission direction switches
- Travel park brake
- 2/4 wheel drive/range selector
- Hazard flasher

Armrest Controls - Two dual axis electronic joystick controllers or optional single axis electronic controllers for:

- Swing
- Boom hoist
- Main (rear) winch
- Auxiliary (front) winch
- Winch high/low speed switch(es)
- Warning horn button
- Swing park brake switch
- Engine throttle lock switch
- Engine set/resume switch
- Cab tilt
- Telescope override

Outrigger Controls - Hand held control box with umbilical cord gives the operator the freedom to view operation while setting the outriggers.

Foot Controls

- Boom telescope
- Swing brake
- Service brake
- Engine throttle

Upper Right Console - Controls and indicators for:

- Engine ignition
- Engine stop
- Function lockout
- Front windshield wiper and washer
- Cab lights and upper frame lights
- Horn
- Dome light with switch
- E- stop switch
- Radio
- DRI on/off selection
- HVAC controller
- Boom floodlights
- Rotating beacon/Strobe light
- Top hatch wiper washer
- Winch(es) disable
- Engine indicator gauge
- 360° swing lock - optional

Internal RCL Light Bar - Visually informs the operator when crane is approaching maximum load capacity with a series of green, yellow, and red lights.

Integrated Third Wrap Function Kickout - Link-Belt Pulse 2.0 color display visually and audibly warns the operator when the wire rope is on the first/bottom layer and provides a function kickout when the wire rope is down to the last three wraps.

External RCL Light Bar - Optional - Visually informs the ground crew when crane is approaching maximum load capacity with a series of green, yellow, and red lights.

Rear Right Side Panel

- 12V accessory outlet (10amp)
- USB charge port

Camera Display - Located on the right A- post with an adjustable mount

- Displays right side of upper
- Displays main and auxiliary winches
- Displays rear view

Diagnostic Center - Located on the right rear wall behind the seat.

- Engine diagnostic
- RCL CANBUS diagnostic
- Master controller CANBUS diagnostic

Fuse & Relay Panel - Located on the left rear wall behind the seat.

Link-Belt Pulse 2.0 - The Link-Belt in-house designed, total crane operating system that utilizes a 10 in touch screen color display with integrated RCL and engine data, advanced diagnostics and systems monitoring, Wi-Fi capable for remote software updates, operator customizable, and a readout and operator interface for the following systems:

- **Rated capacity limiter** – LCD graphic audio – visual warning system integrated into the dash with anti – two block and function limiter. Operating data includes:
 - RCL controller USB diagnostic
 - Crane configuration
 - Boom length and angle
 - Boom head height
 - Allowed load and % of allowed load
 - RCL light bar
 - Boom angle
 - Radius of load
 - Actual load
 - Wind speed
 - Highlighted unit of measurement on working screen
 - Telescope operation displayed in real time
 - Steer mode selector
 - Outrigger position sensing
 - Drum Rotation direction indication
 - Third wrap indicator - optional
 - Diagnostics
 - Operator settable alarms with function kickout (include):
 - Maximum and minimum boom angles
 - Maximum tip height
 - Maximum boom length
 - Swing left/right positions
 - Operator defined area (imaginary plane)
 - **Cab Instrumentation**
 - Speedometer
 - Tachometer
 - Engine water temperature
 - Fuel level
 - Hydraulic oil temperature
 - Stop engine
 - Check engine
 - Wait to start
 - Transmission oil temperature
 - Diesel exhaust fluid (DEF) level⁽¹⁾
 - Engine air filter high restriction light
 - Regeneration light⁽¹⁾
 - Regeneration inhibit switch⁽¹⁾
 - Regeneration initiate switch⁽¹⁾
 - High exhaust temperature light⁽¹⁾
 - Regeneration disabled light⁽¹⁾
 - Swing park brake light
 - Engine speed
 - Engine oil pressure light
 - Battery voltage
 - Fuel rate (gal/hr)
 - Engine load
 - Engine Diagnostics
- ⁽¹⁾ (Stage V/Tier 4F engine only)
- **Telematics** - Cellular based data logging and monitoring system that provides:
 - Location and operational settings
 - Routine maintenance
 - Crane and engine monitoring
 - Diagnostic and fault codes

■ Swing

Motor/Planetary - Bi- directional hydraulic swing motor mounted to a planetary reducer for 360° continuous smooth swing at 1.9 rpm

Swing Park Brake - 360°, electric over hydraulic, (spring applied/hydraulic released) multi- disc brake mounted on the speed reducer. Operated by a switch from the operator's cab.

Swing Brake - 360°, foot operated, speed reducing system with disc brake hold feature

Swing Lock - Two- position swing lock (boom over front or rear) operated from the operator's cab.

360° Positive Swing Lock - Optional - Meets New York City requirement

■ Electrical

Swing Alarm - Audio/video warning device signals when the upper is swinging.

Lights

- Two LED working lights on front of the cab
- Two amber strobe lights at rear of the upper frame
- LED Boom floodlight - Dual
- LED Frame work lights - right front, left rear, and work platform
- One LED working light on top of cab - optional
- Boom floodlight - High intensity remote controlled - optional
- LED electrical compartment

■ Load Hoist System

Load Hoist Performance

Main (Rear) and Auxiliary (Front) Winches - 3/4 in (19mm) Rope										
Layer	Maximum Line Pull		Normal Line Speed		High Line Speed		Layer		Total	
	lb	kN	ft/min	m/min	ft/min	m/min	ft	m	ft	m
1	23,632	105.12	150	45.7	241	73.5	115	35.1	115	35.1
2	21,616	96.15	164	50.0	264	80.5	125	38.1	240	73.2
3	19,917	88.60	178	54.3	286	87.2	136	41.5	376	114.6
4	18,465	82.14	192	58.5	309	94.2	147	44.5	522	159.1
5	17,211	76.56	206	62.8	331	100.9	157	47.9	679	207.0
6	16,116	71.69	220	67.1	354	107.9	168	51.2	847	258.2

Wire Rope Application		in	mm	Type	lb	kg
Main (Rear) Winch	Standard	3/4	19	37x7 rotation resistant - right lang lay (Type KC)	16,000	7 257.5
	Optional	3/4	19	35x7 rotation resistant - right lang lay (Type CC)	17,160	7 783.6
Auxiliary (Front) Winch	Standard	3/4	19	37x7 rotation resistant - right lang lay (Type KC)	16,000	7 257.5
	Optional	3/4	19	35x7 rotation resistant - right lang lay (Type CC)	17,160	7 783.6

Main and Auxiliary Winches

- Axial piston (2- speed) motors driven through planetary reduction unit for positive control under all load conditions.
- Grooved lagging
- Power up/down mode of operation
- Hoist drum cable follower
- Drum rotation indicator
- Drum diameter: 15 in (38.1cm)
- Rope length:
 - Main: 850 ft (259m)
 - Auxiliary: 600 ft (182.9m)
- Maximum rope storage: 850 ft (259m)
- Terminator style socket and wedge

■ Hydraulic System

Counterbalance Valves - All hoist motors, boom extend cylinders, and boom hoist cylinders are equipped with counterbalance valves to provide load lowering and prevents accidental load drop when hydraulic power is suddenly reduced.

■ Counterweight

Standard - Total of 28,800 lb (13.2t) counterweight consisting of three counterweight slabs pinned to the upper with capacities for:

- 0 lb (0t) counterweight
- 9,600 lb (4.4t) counterweight
- 19,200 lb (8.8t) counterweight
- 28,800 lb (13.2t) counterweight

Hydraulic counterweight removal activated by upper frame mounted toggle switch.

Carrier

General

- 10 ft 11 in (3.33m) wide
- 14 ft 4 in (4.37m) wheelbase (centerline of first axle to centerline of second axle)

Frame - Box- type, torsion resistant, welded construction made of high tensile steel. Equipped with front and rear towing and tie- down lugs, tow connections, and access ladders.

- Six points of access
- Flat deck
- Three lockable storage boxes

Pintle Hooks - Optional - Front and rear available

Outriggers

Boxes - Two double box, front and rear welded to carrier frame

Beams and Jacks - Four single stage beams that are hydraulically controlled from the operator's cab with integral check valves.

V- CALC - Variable confined area lifting capabilities that are incorporated directly into the Pulse 2.0 display allowing multiple outrigger configurations of fully extended, intermediate, and fully retracted, with live on screen working radii, utilizing 360° charts, and swing arrest.

Pontoons - Four lightweight, serviceable, quick release, 24 in diameter (60.96cm), steel pontoons with contact area of 452 in² (2 916cm²) can be stored for road travel in storage racks on the carrier.

Main Jack Reaction - 112,600 lb (51 074kg) force and 249 psi (1 216kPa) ground bearing pressure.

Steering and Axles

Steering - Four independent modes consisting of two wheel front, two wheel rear, four wheel, and crab. Each mode is controlled from the Pulse 2.0 display.

Drive - Two modes: 4 x 2 and 4 x 4 for off highway travel

Axle 1 - Steered, non- driven for 4 x 2 and steered, driven for 4 x 4

Axle 2 - Steered, driven

Emergency Steer System - Optional

Suspension

Front - Rigid mount to the carrier frame

Rear - The rear axle is suspended on the oscillation cylinders with motion of the axle controlled by a four bar greaseless linkage system. The oscillation cylinders lockout when the upper structure rotates 2.5° past centerline.

Hydro- gas Rear Suspension - Optional

Ride Height Adjustment - Suspension can be lowered for transport using a carrier mounted toggle switch from ground level.

Tires and Wheels

Front and Rear - Four (single) 29.5 x 25- 34 ply rating, earthmover type tires on steel disc wheels

- Spare tires and wheels - optional

Brakes

Service - Full hydraulic, dual circuit, disc type brakes on all wheel ends

Parking/Emergency - Spring applied type, acting on front axle

Electrical

Two batteries provide 24 volt starting and operation

Lights (LED)

- All lights are LED.
- Front lighting includes two main headlights and two parking/directional indicators.
- Side lighting includes outrigger lights and two parking/directional indicators per side.
- Rear lighting includes two directional indicators, two parking/brake lights, and two reversing lights.
- Electrical and battery compartment lights.

Engine

Specification	Cummins QSB	
Emissions Compliance Level:	Stage V/Tier 4F ⁽¹⁾	Tier 3/Stage IIIA ⁽²⁾
Numbers of Cylinders	6	6
Cycle	4	4
Bore and Stroke: inch (mm)	4.21 x 4.88 (107 x 124)	4.21 x 4.88 (107 x 124)
Piston Displacement: in ³ (L)	408 (6.7)	408 (6.7)
Max. Brake Horsepower: hp (kW)	232 (173) @ 2,000 rpm	240 (179) @ 2,000 rpm
Peak Torque: ft lb (Nm)	700 (949) @ 1,500 rpm	728 (987) @ 1,500 rpm
Electric/starting systems: volts	24/24	24/24
Alternator: amps	140	140
Crankcase Capacity: qt (L)	15 (14.2)	15 (14.2)

- Water/fuel separator w/ heater and water in fuel (WIF) sensor
- 120- volt block heater - Stage V/Tier 4F
- 220- volt block heater - Tier 3/Stage IIIA
- Grid heater - 112 amp
- Mechanically driven, variable speed, engine controlled, viscous fan clutch
- ⁽¹⁾ Can only be sold and/or operated where Stage V/Tier 4F off- highway emission standards are accepted.
- ⁽²⁾ Can only be sold and/or operated where Tier 3/Stage IIIA off- highway emission standards are accepted.

Transmission

Powershift - Three speed with high/low range for 6 forward and 6 reverse gears. Front axle disconnect for two or four wheel drive. Front axle disconnects in high range.

■ Fuel Tank

One 75 gallon (283.9L) capacity tank

Diesel Exhaust Fluid (DEF) tank

- One 10 gal (37.9L) capacity tank

■ Hydraulic System

All functions are hydraulically powered allowing positive precise control with independent or simultaneous operation of all functions.

Main Pumps

- Two variable displacement, load sense, piston pumps with anti- stall for the boom hoist, boom extend, front winch and rear winch.
- One three section fixed displacement gear pump for the oil cooler, swing, steer, brakes, and outrigger.
- Combined pump capacity of 128 gpm (484.5Lpm)

Hydraulic Reservoir - 183 gal (692.7L) capacity equipped with sight level gauge. Diffusers built in for deaeration.

Filtration - One 5 micron, full flow return line filter. Accessible for easy filter replacement.

Hydraulic Oil Coolers - One carrier mounted cooler removes heat from the hydraulic oil. Remote mounted on right side of the carrier.

■ Pump Drive

All pumps are mechanically driven by the diesel engine.

■ Maximum Speed

15 mph (24.14 km/h)

■ Gradeability

Counterweight	Ascending		Descending		Side	
	Degrees	% Grade	Degrees	% Grade	Degrees	% Grade
0	17.0	31%	2.0	3%	3.0	5%
9,600 lb (4.4t)	15.0	27%	12.0	21%		
19,200 lb (8.8t)	14.0	25%	14.0	25%		
28,800 lb (13.2t)	13.0	23%	13.0	23%		

Axle Loads

Base Machine Includes: two winches with cable followers, standard wire rope length, full counterweight, dual boom flood lights, auxiliary lifting sheave, two- piece fly, 60t hookblock, and 10t hookball.		Gross Vehicle Weight ⁽¹⁾		Front Axles		Rear Axles	
		lb	kg	lb	kg	lb	kg
		Stage V/Tier 4F	122,257	55 455	60,134	27 277	62,123
Stage 3A/Tier 3	122,477	55 555	60,195	27 304	62,283	28 252	
Remove	Full 28,800 lb (13.2t) Counterweight	- 29,067	- 13 185	10,157	4 608	- 39,224	- 17 792
	Two- piece Fly	- 2,650	- 1 203	- 4,574	- 2 075	1,924	873
	Auxiliary Lifting Sheave	- 110	- 50	- 324	- 147	214	97
	60t Hookblock at Bumper	- 1,400	- 636	- 2,124	- 964	724	329
	10t Hookball and Bumper	- 580	- 264	- 880	- 400	300	137

Tire	Maximum Allowable Axle Load @ 15 mph (24.1km/h)
29.5 x 25 (34- PR)	72,800 lb (33 021kg)

⁽¹⁾ Adjust gross vehicle weight and axle loading according to component weight.

Note: All weights are ±3%.

■ Paint

Entire machine is pre-painted and oven baked with Highsolid Paint (2 part epoxy/polyester) and/or (2 part epoxy primer/2 part polyurethane top coat). Standard Link-Belt Red, Link-Belt Gray, and Gloss Black colors apply.

■ Additional Equipment Options

- Spark arrestor (export only)
- Engine air intake shutoff valve
- Cold weather package (domestic only)
- Arctic weather package (domestic only)
- Filter kits

General Dimensions

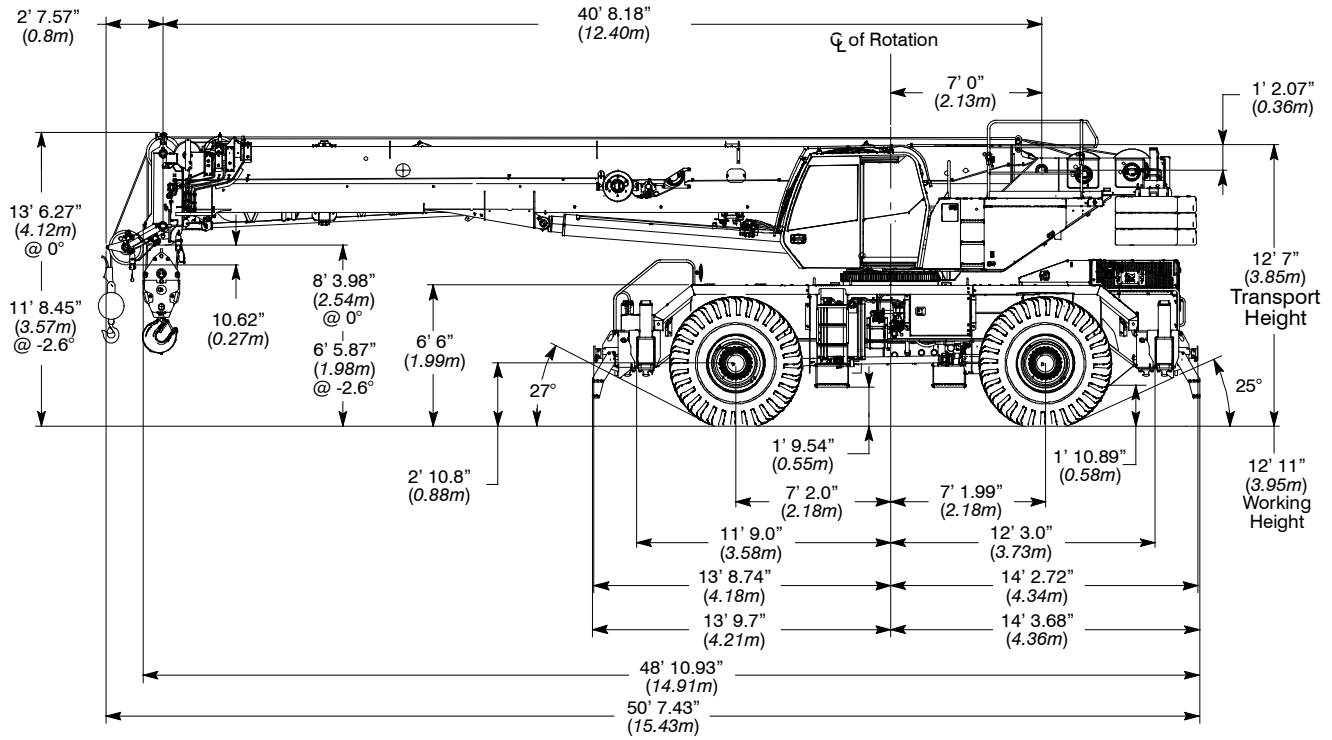

Turning Radius - Front Wheel (4x2) Steering		
	English	Metric
Wall to wall over carrier	46' 10"	14.30m
Wall to wall over boom attachment	58' 3"	17.80m
Curb to curb	45' 3"	13.80m
Centerline of tire	43' 11"	13.40m

Turning Radius - All Wheel (4x4) Steering		
	English	Metric
Wall to wall over carrier	27' 3"	8.30m
Wall to wall over boom attachment	40' 11"	12.50m
Curb to curb	25' 4"	7.70m
Centerline of tire	24' 0"	7.30m

Tail Swing		
	English	Metric
With counterweight	14' 2"	4.32m
Without counterweight	13' 0"	3.96m

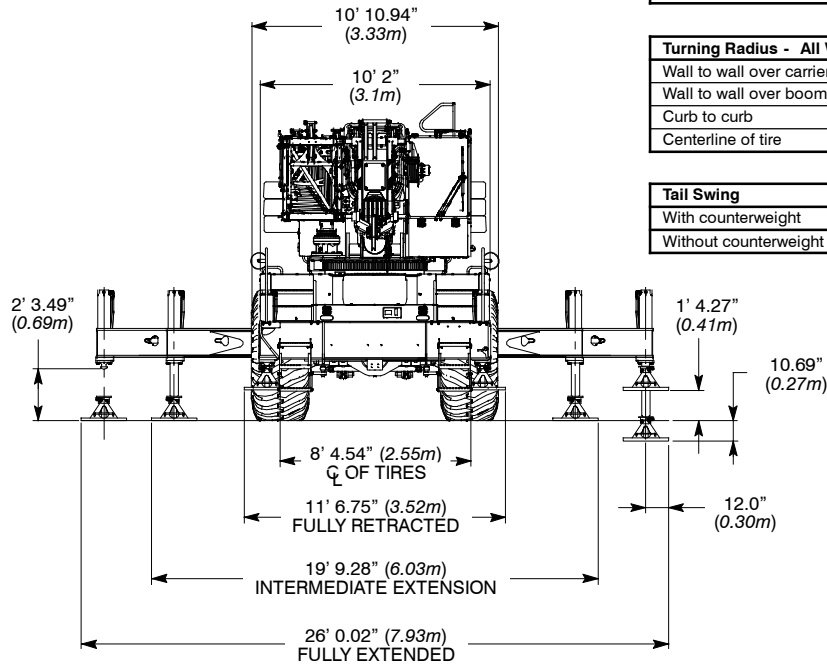

Not To Scale

Working Range Diagram Main Boom + Fly

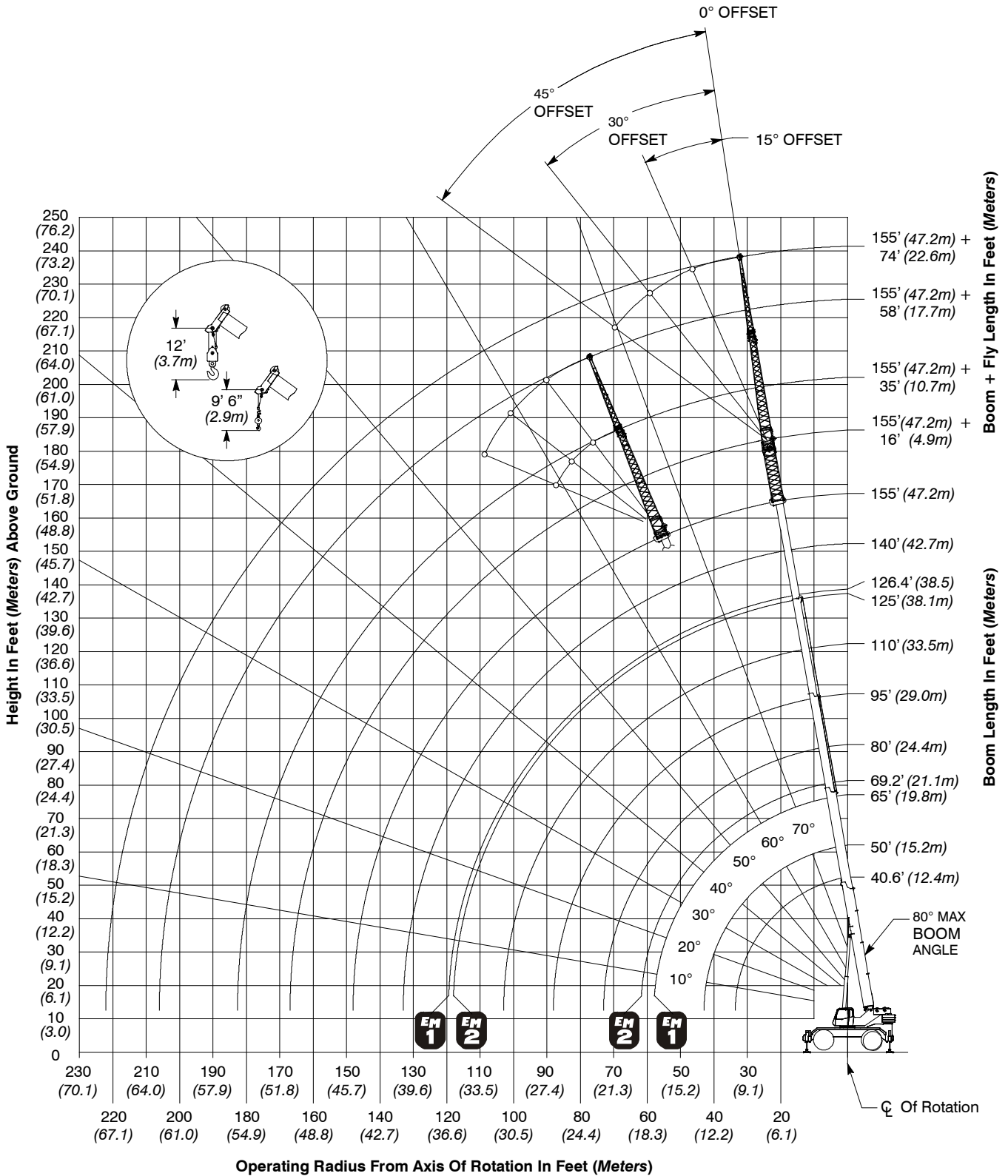



Boom Extend Modes

	Boom Length		Telescope Length			
	ft	m	T4	T3	T2	T1
*	40.6	12.37				
	50	15.24	11%	11%	11%	
*	65	19.81	28%	28%	28%	
	80	24.38	46%	46%	46%	
*	95	28.96	63%	63%	63%	
	110	33.53	81%	81%	81%	
*	126.4	38.53	100%	100%	100%	
	140	42.67	100%	100%	100%	48%
*	155	47.24	100%	100%	100%	100%

	Boom		Telescope Length			
	ft	m	T4	T3	T2	T1
*	40.6	12.37				
	50	15.24				33%
*	69.2	21.09				100%
	80	24.38	13%	13%	13%	100%
*	95	28.96	30%	30%	30%	100%
	110	33.53	48%	48%	48%	100%
*	125	38.10	65%	65%	65%	100%
	140	42.67	83%	83%	83%	100%
*	155	47.24	100%	100%	100%	100%

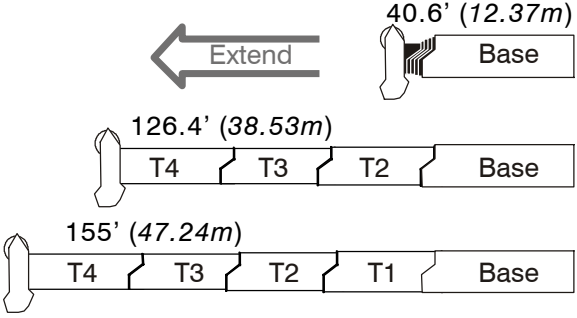





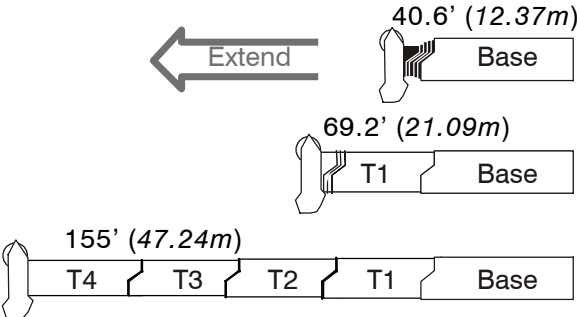

* Denotes boom lengths charted for main boom and fly capacities.

Main Boom Lift Capacity Charts - Imperial

28,800 lb Counterweight - Fully Extended Outriggers - 360° Rotation (All Capacities Are Listed In Pounds)											
Radius (ft)	Boom Length (ft)									Radius (ft)	
	40.6	50.0- 50.5	65- 69.2	80	95	110	125- 126.4	140	155		
10	180,000*									10	
10	164,100	115,000	97,000							10	
12	147,000	115,000	97,000	55,500						12	
15	126,700	115,000	93,400	55,500						15	
20	93,300	92,400	78,700	55,500	55,500	49,800				20	
25	72,400	71,700	67,600	55,500	53,100	45,900	35,900			25	
30	58,300	57,600	56,700	55,500	47,000	40,900	35,900	26,100		30	
35		49,700	51,300	52,200	42,000	36,600	32,400	26,100	19,800	35	
40		42,000	43,600	44,500	37,900	33,000	29,400	26,100	19,800	40	
45			36,200	37,100	33,500	30,000	26,800	24,500	19,800	45	
50			30,200	31,200	27,700	27,400	24,600	22,400	19,800	50	
55			25,500	26,500	23,600	24,100	22,600	20,700	19,200	55	
60			16,700	22,800	21,900	20,500	20,800	19,100	17,700	60	
65				19,700	20,400	17,500	18,200	17,600	16,200	65	
70				17,200	17,900	16,200	15,700	16,200	15,100	70	
75					15,800	15,100	13,800	14,400	14,000	75	
80					14,000	14,200	12,400	13,600	13,000	80	
85					12,500	12,900	11,600	12,300	11,400	85	
90						11,500	10,900	11,000	10,100	90	
95							10,300	10,200	9,800	9,000	95
100							9,300	9,600	8,800	7,900	100
105								8,700	7,800	7,000	105
110								7,800	7,000	6,200	110
115								7,100	6,200	5,400	115
120									5,500	4,800	120
125									4,900	4,100	125
130									4,300	3,600	130
135										3,000	135
140										2,600	140
145										2,100	145

* Over Front Only With Special Equipment

This information is not for crane operation. Operator must refer to the in-cab information for crane operation. Rated lifting capacities shown on fully extended outriggers do not exceed 85% of the tipping loads and on tires do not exceed 75% of the tipping loads.

Fly Attachment Lift Capacity Charts - Optional

28,800 lb Counterweight - Fully Extended Outriggers - 360° Rotation
 (All Capacities Are Listed In Pounds)

155 ft Main Boom Length

Radius (ft)	35 ft Manual Offset Fly				58 ft Manual Offset Fly				74 ft Manual Offset Fly				Radius (ft)
	0°	15°	30°	45°	0°	15°	30°	45°	0°	15°	30°	45°	
40	11,200												40
45	11,200												45
50	11,200				7,500				5,300				50
55	11,200	11,700			7,500				5,300				55
60	11,200	11,700			7,500				5,300				60
65	11,200	11,700	11,500		7,500				5,300				65
70	11,200	11,700	11,300	10,100	7,500	7,700			5,300	5,300			70
75	11,200	11,700	11,100	9,900	7,500	7,600			5,300	5,200			75
80	11,200	11,700	10,900	9,800	7,500	7,400	6,400		5,300	5,100			80
85	11,100	11,100	10,600	9,600	7,500	7,300	6,300		5,300	4,900	4,400		85
90	10,300	10,400	10,100	9,500	7,500	7,100	6,200	5,500	5,300	4,800	4,300		90
95	9,300	9,700	9,700	9,400	7,500	7,000	6,100	5,400	5,300	4,700	4,200	3,900	95
100	8,200	8,900	9,100	9,000	7,500	6,800	6,000	5,300	5,300	4,600	4,100	3,800	100
105	7,300	7,900	8,400	8,600	7,500	6,700	5,800	5,200	5,100	4,500	4,000	3,700	105
110	6,500	7,000	7,500	7,800	7,100	6,600	5,700	5,100	5,000	4,300	3,900	3,600	110
115	5,700	6,200	6,600	6,900	6,300	6,400	5,600	5,100	4,900	4,200	3,800	3,600	115
120	5,000	5,500	5,900	6,100	5,600	6,300	5,500	5,000	4,700	4,100	3,700	3,500	120
125	4,400	4,800	5,200	5,400	5,000	5,700	5,400	4,900	4,600	4,000	3,700	3,400	125
130	3,800	4,200	4,500	4,700	4,400	5,100	5,300	4,900	4,300	3,900	3,600	3,400	130
135	3,300	3,700	4,000	4,100	3,900	4,500	5,100	4,800	3,800	3,800	3,500	3,300	135
140	2,900	3,200	3,400	3,500	3,400	4,000	4,500	4,800	3,300	3,800	3,400	3,300	140
145	2,400	2,700	2,900	3,000	3,000	3,500	4,000	4,300	2,900	3,500	3,400	3,200	145
150	2,000	2,300	2,500		2,500	3,100	3,500	3,700	2,400	3,000	3,300	3,200	150
155	1,600	1,900	2,000		2,200	2,600	3,000	3,200	2,100	2,600	3,000	3,100	155
160	1,300	1,500	1,600		1,800	2,200	2,600	2,700	1,700	2,200	2,600	2,800	160
165	1,000	1,100	1,200		1,500	1,900	2,200	2,300	1,400	1,800	2,200	2,400	165
170					1,200	1,500	1,800	1,900	1,000	1,500	1,800	2,000	170
175					900	1,200	1,400			1,200	1,400	1,600	175
180						900	1,100				1,100	1,200	180

This information is not for crane operation. Operator must refer to the in-cab information for crane operation. Rated lifting capacities shown on fully extended outriggers do not exceed 85% of the tipping loads and on tires do not exceed 75% of the tipping loads.

Main Boom Lift Capacity Charts - On Tires

28,800 lb Counterweight - On Tires - Stationary - Boom Centered Over Front Between Tire Tracks (All Capacities Are Listed In Pounds)								
Radius (ft)	Boom Length (ft)						Radius (ft)	
	40.6	50	65	80	95	110		125
12	67,500	68,600						12
15	56,900	58,200						15
20	44,500	45,900	47,100					20
25	35,900	37,300	38,600					25
30	29,500	31,000	32,300	33,100				30
35		25,300	26,900	27,800	28,300			35
40		19,900	21,500	22,400	22,800			40
45			17,400	18,300	18,800	19,200		45
50			14,400	15,300	15,800	16,100	16,300	50
55			12,000	12,800	13,400	13,800	14,000	55
60				10,800	11,400	11,800	12,100	60
65				9,200	9,700	10,100	10,400	65
70				7,800	8,400	8,700	9,000	70
75					7,200	7,500	7,800	75
80					6,200	6,500	6,800	80
85					5,300	5,600	5,900	85
90						4,900	5,100	90
95						4,200	4,400	95
100						3,600	3,800	100
105							3,300	105
110							2,800	110
115							2,300	115

This information is not for crane operation. Operator must refer to the in- cab information for crane operation. Rated lifting capacities shown on fully extended outriggers do not exceed 85% of the tipping loads and on tires do not exceed 75% of the tipping loads.

28,800 lb Counterweight - On Tires - Pick & Carry (Creep) - Boom Centered Over Front (All Capacities Are Listed In Pounds)								
Radius (ft)	Boom Length (ft)							Radius (ft)
	40.6	50	65	80	95	110	125	
12	60,700	61,700						12
15	50,500	51,700						15
20	38,600	39,900	41,000					20
25	30,300	31,700	32,900					25
30	24,200	25,600	27,000	27,700				30
35		21,000	22,400	23,200	23,700			35
40		17,300	18,700	19,600	20,100			40
45			15,900	16,600	17,200	17,600		45
50			13,400	14,300	14,900	15,300	15,600	50
55			11,400	12,300	12,900	13,300	13,600	55
60				10,600	11,100	11,600	11,900	60
65				9,100	9,700	10,100	10,400	65
70				7,800	8,400	8,700	9,000	70
75					7,200	7,500	7,800	75
80					6,200	6,500	6,800	80
85					5,300	5,600	5,900	85
90						4,900	5,100	90
95						4,200	4,400	95
100						3,600	3,800	100
105							3,300	105
110							2,800	110
115							2,300	115

This information is not for crane operation. Operator must refer to the in- cab information for crane operation. Rated lifting capacities shown on fully extended outriggers do not exceed 85% of the tipping loads and on tires do not exceed 75% of the tipping loads.

28,800 lb Counterweight - On Tires - Pick & Carry (2.5 mph) - Boom Centered Over Front
 (All Capacities Are Listed In Pounds)

Radius (ft)	Boom Length (ft)							Radius (ft)
	40.6	50	65	80	95	110	125	
12	47,100	48,000						12
15	38,800	40,000						15
20	29,000	30,300	31,500					20
25	22,200	23,600	24,900					25
30	17,200	18,600	19,900	20,700				30
35		14,900	16,200	17,000	17,500			35
40		11,800	13,300	14,100	14,700			40
45			10,900	11,700	12,300	12,700		45
50			8,900	9,800	10,300	10,700	11,000	50
55			7,200	8,100	8,700	9,100	9,400	55
60				6,700	7,300	7,700	8,000	60
65				5,500	6,000	6,500	6,800	65
70				4,400	5,000	5,400	5,700	70
75					4,100	4,500	4,800	75
80					3,300	3,700	4,000	80
85					2,500	2,900	3,300	85
90						2,300	2,600	90
95						1,700	2,000	95
100						1,200	1,500	100
105							1,000	105

This information is not for crane operation. Operator must refer to the in- cab information for crane operation. Rated lifting capacities shown on fully extended outriggers do not exceed 85% of the tipping loads and on tires do not exceed 75% of the tipping loads.

Link-Belt Cranes Lexington, Kentucky www.linkbelt.com

®Link-Belt is a registered trademark. Copyright 2019. We are constantly improving our products and therefore reserve the right to change designs and specifications.